

# Cartage Tank

**SPECIALLY DESIGNED FOR LIQUID FERTILIZER**

The versatile range of cartage and spray tanks are custom designed with unique features to assist with ease and efficiency during the busy spraying season. They are heavy duty, with a low profile suitable for mounting on a truck, cart or boom. The tanks are purpose built for carting Liquid Fertilizer such as Flexi-N and UAN, and other heavy liquids with a specific gravity of 1.5. Optional extras available.

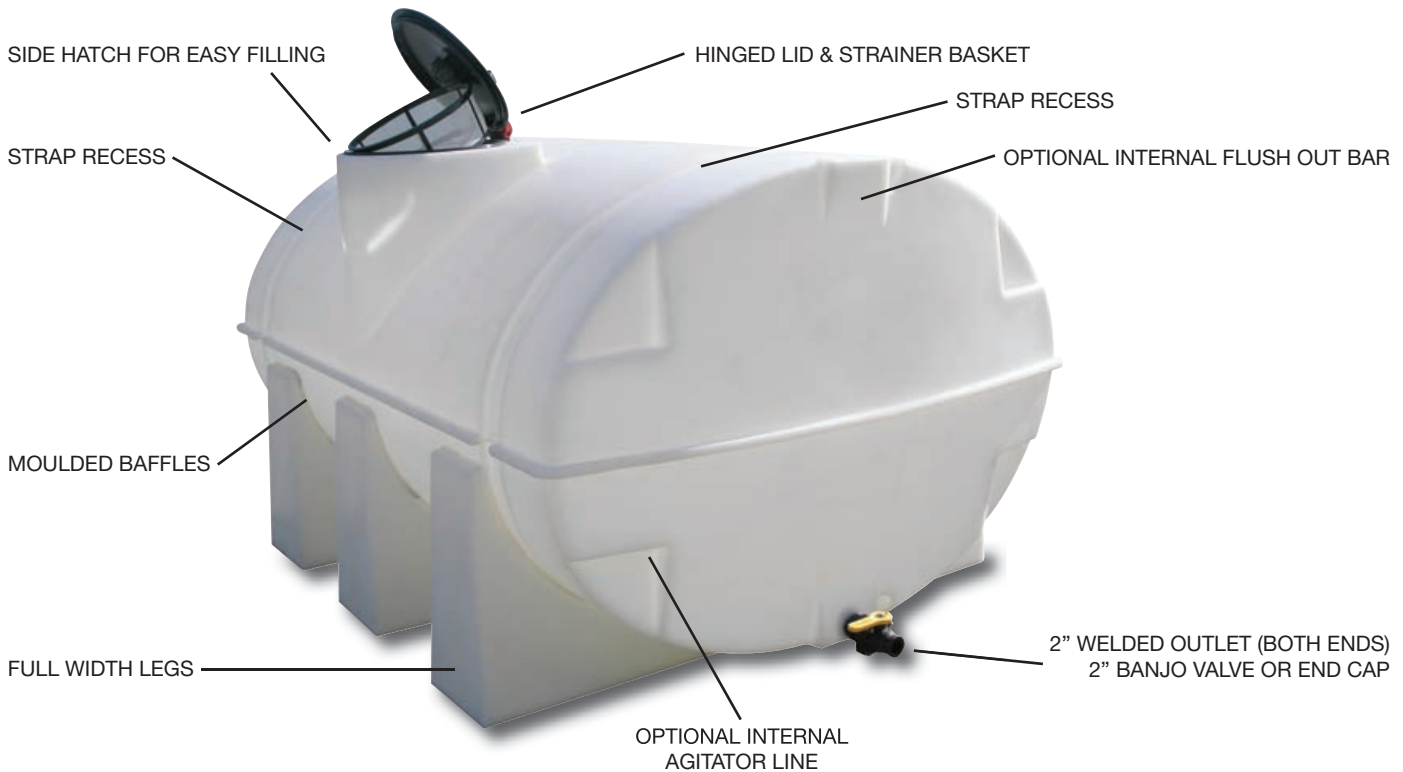

VOLUME (litres)	WIDTH (metres)	LENGTH (metres)	HEIGHT (NO LEGS) (metres)	HEIGHT (WITH LEGS) (metres)
5200	1.84	3.24	1.34	1.40
3400	1.84	2.37	1.26	1.32

## STANDARD FEATURES & FITTINGS

- ✓ 2" Welded outlet with ball valve & camlock adaptor
- ✓ 2" Welded outlet with cap
- ✓ Hinged lid and strainer

## OPTIONAL FEATURES

- ✓ Internal flush out bar
- ✓ 50mm camlock inlet connector
- ✓ Heavy duty poly legs
- ✓ Bridle Straps
- ✓ Internal agitator line

## BENEFITS

- ✓ Heavy duty robust polyethylene construction
- ✓ Handles heavy liquids (SG to 1.5)
- ✓ Quality Banjo 50mm valve with integrated camlock connector
- ✓ Internal moulded baffles to limit surge
- ✓ Side mounted hatch for easy access
- ✓ Lowline construction
- ✓ Heavy central bumper rib

**TANKS WEST**

We Build The Best

# Cartage Tank

SPECIALLY DESIGNED FOR LIQUID FERTILIZER

## 5200 LITRE

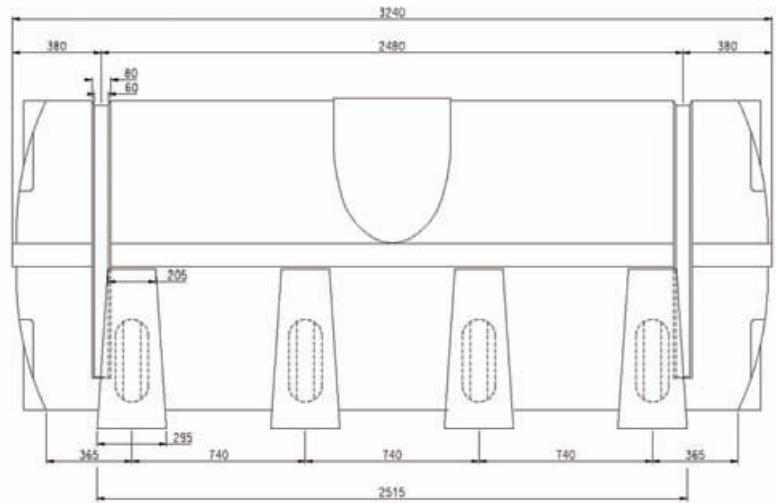
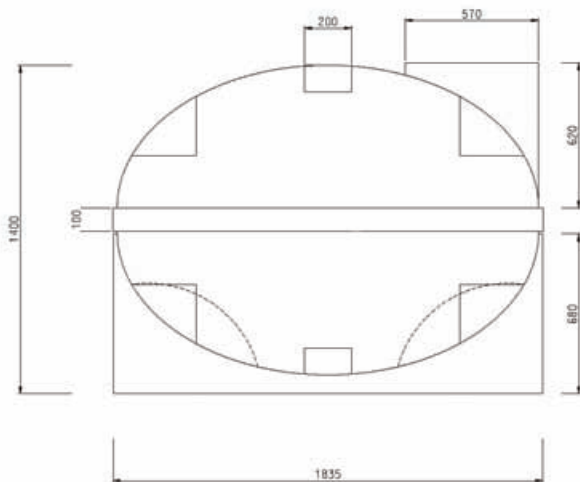

## 3400 LITRE

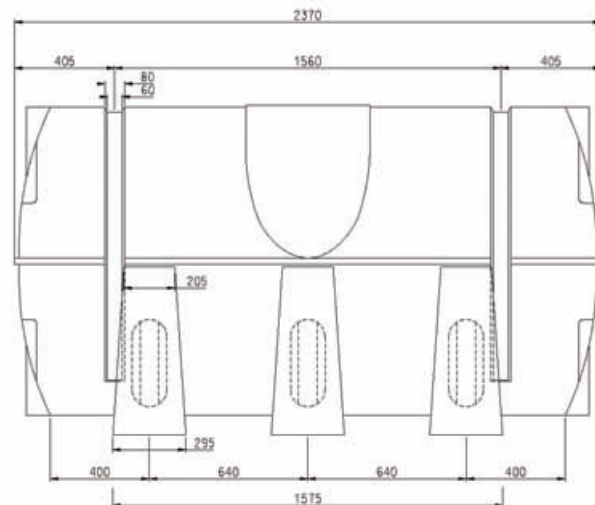
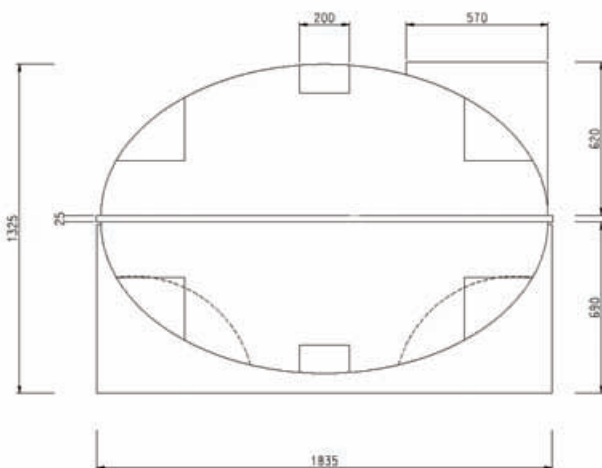

**CALL 1800 812 677**  
[www.tankswest.com.au](http://www.tankswest.com.au)

**TANKS WEST**

We Build The Best